

REVISIONS

ZONE	REV	DESCRIPTION	DATE	APPROVED

8		S64-BA-25	ISOLATOR		
1		PTA-YDC-N5 CAMERA & EQUIPMENT RACK			MAXIMUM WEIGHT OF COMPONETS IS 100 LBS.
	1	1003229	GPS ANTENNA		
	96	NAS517-3-13	SCREW		
	48	NAS1149F0332P	WASHER		
	96	NAS6603-12	SCREW		
	16	39 214-16GN	RECEPTACLE		
	16/-75	39 R4G-2	RETAINING RING, FLUSH		
	16/-75	39 4002-G-1	GROMMET		
	16/-75	39 40S8-2	STUD		
	20/-15	MS21042-3	NUT		
	20/-15	AN5251032R8	SCREW		
	1/-75	-77	COVER		.050, 2024-T3 ALUM ALY PER QQ-A-250/5
	1	-75	COVER PLATE ASSY		
	1	38 PTA-YDC-N5	DIGITAL YAW DAMPENING CAMERA		
	8	37 -73	S64-BA-25		ISOLATOR
	96	MS21209F1-20P	HELICOIL		
	2/-21	-71	ANGLE		M/F: AND10133-1206, 2024-T3511 ALUM ALY PER QQ-A-200/3
	1/-13	-65	AIR DAM BRACKET		.050, 2024-T3 ALUM ALY PER QQ-A-250/5
	1/-13	-64	AIR DAM BRACKET		.050, 2024-T3 ALUM ALY PER QQ-A-250/5
	1	-63	AIR DAM		.050, 2024-T3 ALUM ALY PER QQ-A-250/5
	1/-15	-61	DOUBLER		.050, 2024-T3 ALUM ALY PER QQ-A-250/5
	2/-15	-59	ANGLE BRACKET		.050, 2024-T3 ALUM ALY PER QQ-A-250/5
	1/-15	-57	VERTICAL SHIELD		.050, 2024-T3 ALUM ALY PER QQ-A-250/5
	7	-55	ZEE ANGLE		M/F: AND10138-0504 EXTRU, 2024-T3511 PER QQ-A-200/3
	1	-53	ANTENNA DOUBLER		.050, 2024-T3 ALUM ALY PER QQ-A-250/5
	1	-51	BELLY DOUBLER		.050, 2024-T3 ALUM ALY PER QQ-A-250/5
	1	-23	PILLOW BLOCK ASSY, 1.00 DIA		
	1	-21	GUSSET		.125, 6061-T6 ALUM ALY PER QQ-A-250/11
	4	-19	PILLOW BLOCK ASSY, 1.00 DIA		
	4	-17	PILLOW BLOCK ASSY, .75 DIA		
	1	-15	VERTICAL SHIELD ASSY		
	1	-13	AIR DAM ASSY		
	1	32, 33 -11	EQUIPMENT PLATE		
		41 -5	EQUIPMENT INSTALLATION		
	1	-3	COMPONET REMOVAL		
		41 -1	AIRCRAFT MODIFICATION		

ZONE	REV	NOTE	PART NO.	NOMENCLATURE OR DESCRIPTION	MATERIAL/SPECIFICATION	ITEM NO.
------	-----	------	----------	-----------------------------	------------------------	----------

PARTS LIST

DIMENSIONS ARE IN INCHES  
 TOLERANCES:  
 .XX = ±.03  
 .XXX = ±.015  
 ANGLES ±0°-30°

NOTICE - This drawing is the property of Aviation Engineering Consultants of USA, LLC, and any disclosure of its contents to others is given in confidence. It must not be reproduced or copied in whole or in part or used in any way except with specific approval and permission of the General Manager of Aviation Engineering Consultants of USA, LLC.



STRESS *f Brown* 08/01/2010  
 CHECK *f Brown* 08/01/2010  
 DRAWN *f Brown* 08/01/2010  
 APPRVD *f Brown* 08/01/2010

TITLE PIPER AZTEC CAMERA PROVISIONS & INSTL  
 DWG. NO. 00-1500-01-01-xxx REV. -  
 SCALE NOTED SHEET 1 OF 21

**GENERAL NOTES  
(UNLESS OTHER WISE SPECIFIED)**

1. Fabricate per AC 43.13.
2. Assembly shop practice per AC 43.13.
3. Odd dash numbers shown – next even dash number opposite.
4. Equally spaced attachment tolerance to be  $\pm 0.100$ ".
5. Attachments located from part edge  $2D+.060$ " for details, 2D minimum on assembly, 2D from joggles and adjacent structure.
6. Minimum attachment spacing to be  $4D+.060$ " center to center, max spacing 6D.
7. Remove all burrs and sharp edges.
8. Heat treat 2024-0 to 2024-T42 and 7075-0 to 7075-T62 per Mil-H-6088.
9. NOT USED
10. Identify per MIL-STD-130 using rubber stamp or and written with indelible ink. Small assemblies may be tagged.
11. Alodine all aluminum parts per Mil-C-5541.
12. Epoxy prime per Mil-P-23377.
13. NOT USED
14. Fastener symbols per NAS 523.
15. Symbols + between end fastener symbols indicate identical fasteners equally spaced.
16. Install solid rivets per AC 43.13-1A. Install all other fasteners per manufacturer's instructions.
17. Torque per AC 43.13-1A or MIL-N-25027.
18. Install safety wire per AC 43.13-1A or MS33540.
19. Free flanges angular tolerance  $\pm 5$  degrees (flanges not attached at next assy).
20. Restrained flanges angular tolerance  $\pm 1.5$  degrees (flanges attached at next assy).
21. Faying surface seal all external skin mating joints and install fasteners wet using PR1431G, PR1422, or P/S 870C sealant.
22. Fillet or brush coat edges of mating parts using PR1422-B2, CS3204 class B, PR1422, or P/S 890 class B sealant.
23. NOT USED
24. All bend relief's R .16.
25. Flange corner radii are to be R .25.
26. Pilot holes #40 drill for next assy fastener locations may be added or deleted by mfg.
27. All dimensions are prior to finish applications.
28. Install per the manufacturer's instructions.

29 REMOVE EXISTING EQUIPMENT:

- a) REMOVE CABIN SEATING.
- b) REMOVE CABIN SEAT TRACKS
- c) REMOVE CABIN FLOOR PANELS.

IF REQUIRED:

- d) REMOVE ADF ANTENNA (CLOTHESLINE).
  - d1) REMOVE LOOSE HARDWARE FROM VERTICAL STABILIZER.
  - d2) REMOVE HARDWARE FROM FORWARD ATTACHMENT.
    - d2.1) PREP AND PRIME EXPOSED SURFACES.
- e1) REMOVE ANTI-COLLISION BEACON FROM BOTTOM OF ACFT.  
PREP AND PRIME EXPOSED SURFACES. DO NOT PLUG OPEN HOLES.
- e2) REMOVE ANTI-COLLISION BEACON DOUBLER. PREP AND PRIME EXPOSED SURFACES. DO NOT PLUG OPEN HOLES.
- e3) CAP AND STOW ANTI-COLLISION BEACON WIRING. SO NOTE IN MAINTENANCE MANUAL.

DIMENSIONS ARE IN INCHES  
TOLERANCES:  
.XX =  $\pm 0.03$   
.XXX =  $\pm 0.015$   
ANGLES  $\pm 0^{\circ}-30'$

NOTICE - This drawing is the property of Aviation Engineering Consultants of USA, LLC, and any disclosure of its contents to others is given in confidence. It must not be reproduced or copied in whole or in part or used in any way except with specific approval and permission of the General Manager of Aviation Engineering Consultants of USA, LLC.



**AVIATION ENGINEERING  
CONSULTANTS of USA, LLC**  
Cape Coral, Fl. 33990  
800-977-1992

TITLE PIPER AZTEC CAMERA PROVISIONS & INSTL

DWG. NO. 00-1500-01-01-xxx REV. -

SCALE NOTED SHEET 2

NOTES CONTINUED FROM SHEET 2

▷ MATERIAL: 2024-T3 ALUM ALY PER QQ-A-250/5.

▷ ALTERNATE MATERIAL: 6061-T6 OR -T651 ALUM ALY PER QQ-A-250/11.

▷ MATERIAL: 2024-T351 ALUM ALY PER QQ-A-250/5.

▷ ALTERNATE MATERIAL: 6061-T6 OR -T651 PER QQ-A-250/11.

▷ ALTERNATE: AN960-10L WASHER.

▷ MATERIAL: 2024-T3511 ALUM ALY PER QQ-A-200/3.

▷ ALTERNATE MATERIAL: 6061-T4, -T42, -T4510 OR -T4511 ALUM ALY PER QQ-A-200/8.

▷ PART NUMBER OF BARRY CONTROLS.

▷ PART NUMBER OF PICTOMETRY.

▷ PART NUMBER OF CAMLOC. INSTALL PER MFG RECOMMENDATIONS.

▷ REMOVE EXTG FASTENR - INSTALL INDICATED FASTENER

41 FOR NORMAL AIRCRAFT OPERATIONS, REMOVE THE -5 EQUIPMENT INSTALLATION COMPONETS, AND INSTALL THE -75 COVER PLATE.

FOR PHOTOGRAPHY OPERATIONS, REMOVE THE -75 COVER PLATE AND INSTALL THE -5 EQUIPMENT INSTALLATION COMPONETS.

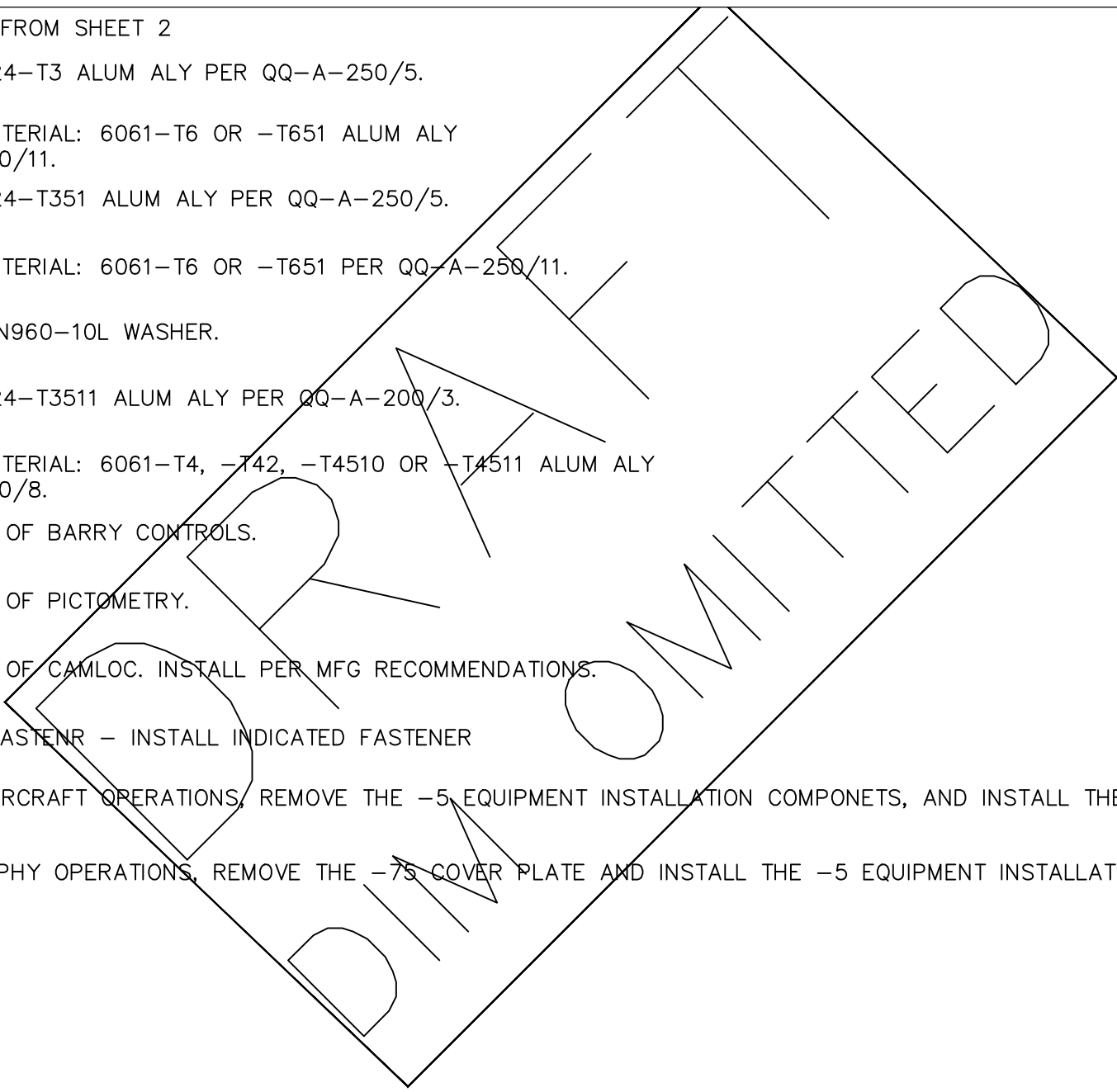

DIMENSIONS ARE IN INCHES  
 TOLERANCES:  
 .XX = ±.03  
 .XXX = ±.015  
 ANGLES ±0°-30'

NOTICE - This drawing is the property of Aviation Engineering Consultants of USA, LLC, and any disclosure of its contents to others is given in confidence. It must not be reproduced or copied in whole or in part or used in any way except with specific approval and permission of the General Manager of Aviation Engineering Consultants of USA, LLC.



AVIATION ENGINEERING  
 CONSULTANTS of USA, LLC  
 Cape Coral, Fl. 33990  
 800-977-1992

TITLE PIPER AZTEC CAMERA PROVISIONS & INSTL

DWG. NO. 00-1500-01-01-xxx REV. -

SCALE NOTED SHEET 3

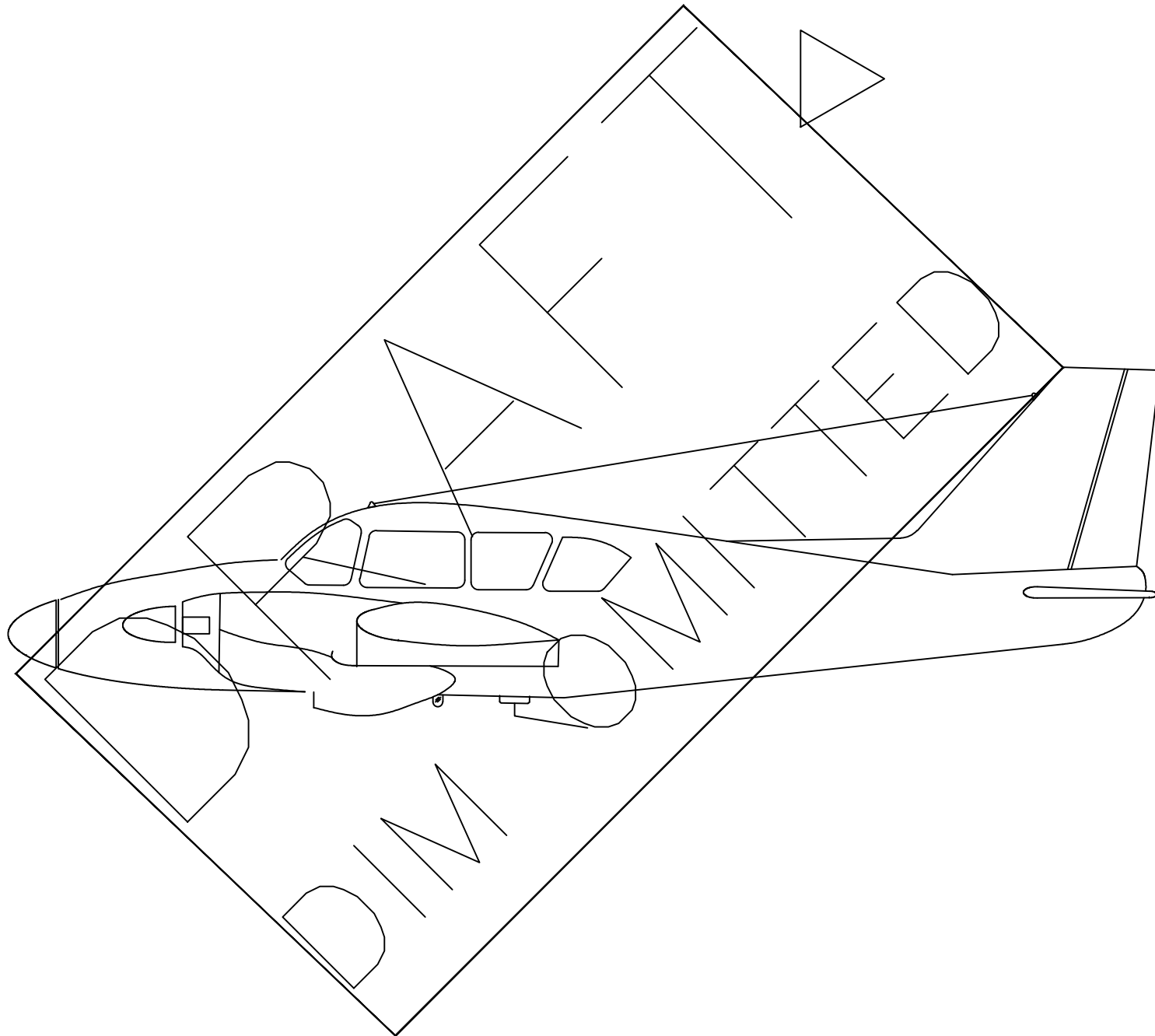

DIMENSIONS ARE IN INCHES  
 TOLERANCES:  
 .XX = ±.03  
 .XXX = ±.015  
 ANGLES ±0°-30'

NOTICE - This drawing is the property of Aviation Engineering Consultants of USA, LLC, and any disclosure of its contents to others is given in confidence. It must not be reproduced or copied in whole or in part or used in any way except with specific approval and permission of the General Manager of Aviation Engineering Consultants of USA, LLC.



**AVIATION ENGINEERING  
 CONSULTANTS of USA, LLC**  
 Cape Coral, Fl. 33990  
 800-977-1992

TITLE PIPER AZTEC CAMERA PROVISIONS & INSTL

DWG. NO.  
 00-1500-01-01-xxx REV. -

SCALE NOTED SHEET 4

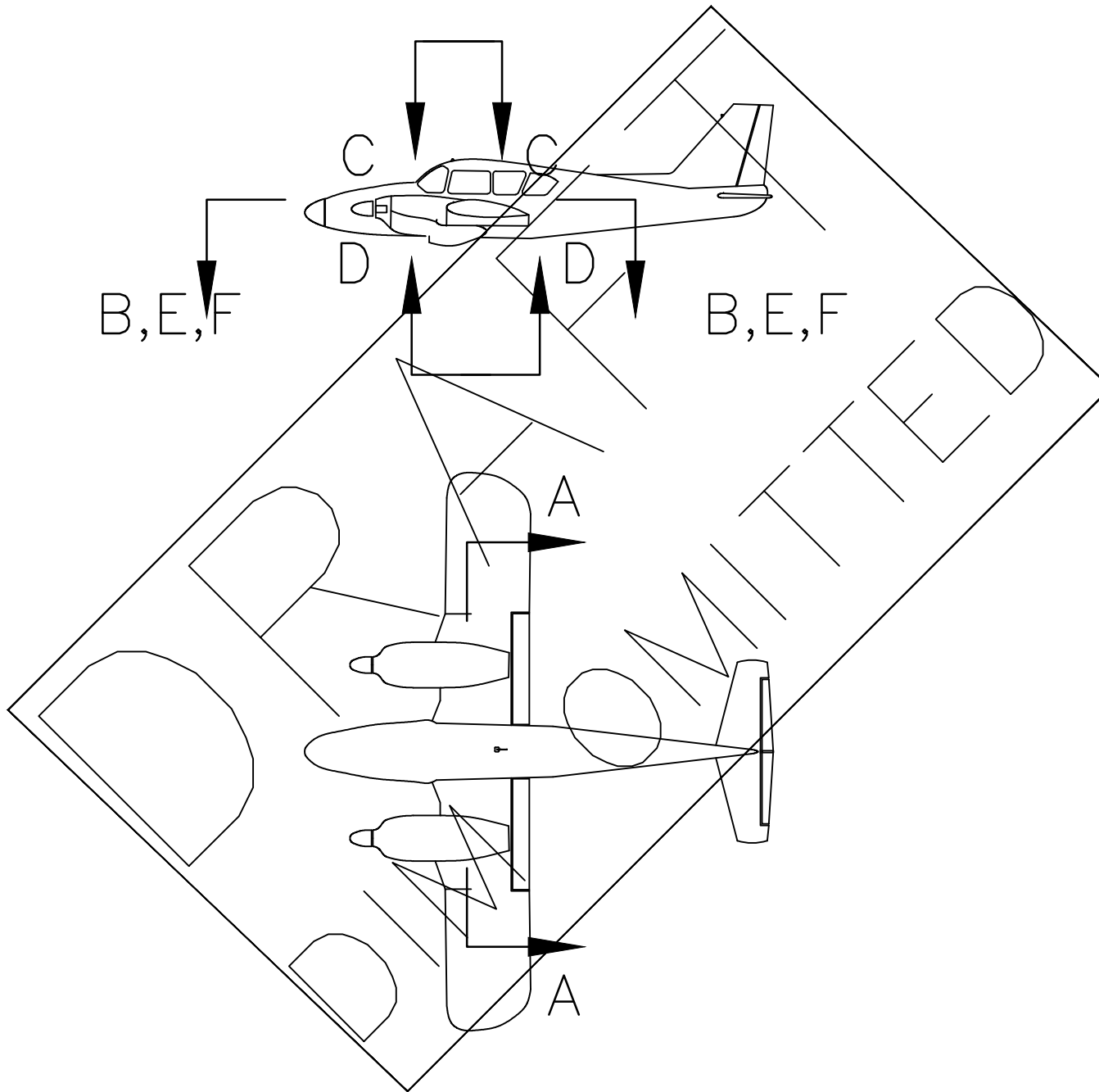

DIMENSIONS ARE IN INCHES  
 TOLERANCES:  
 .XX = ±.03  
 .XXX = ±.015  
 ANGLES ±0°-30'

NOTICE - This drawing is the property of Aviation Engineering Consultants of USA, LLC, and any disclosure of its contents to others is given in confidence. It must not be reproduced or copied in whole or in part or used in any way except with specific approval and permission of the General Manager of Aviation Engineering Consultants of USA, LLC.



AVIATION ENGINEERING  
 CONSULTANTS of USA, LLC  
 Cape Coral, Fl. 33990  
 800-977-1992

TITLE PIPER AZTEC CAMERA PROVISIONS & INSTL

DWG. NO.  
 00-1500-01-01-xxx REV. -

SCALE NOTED SHEET 5

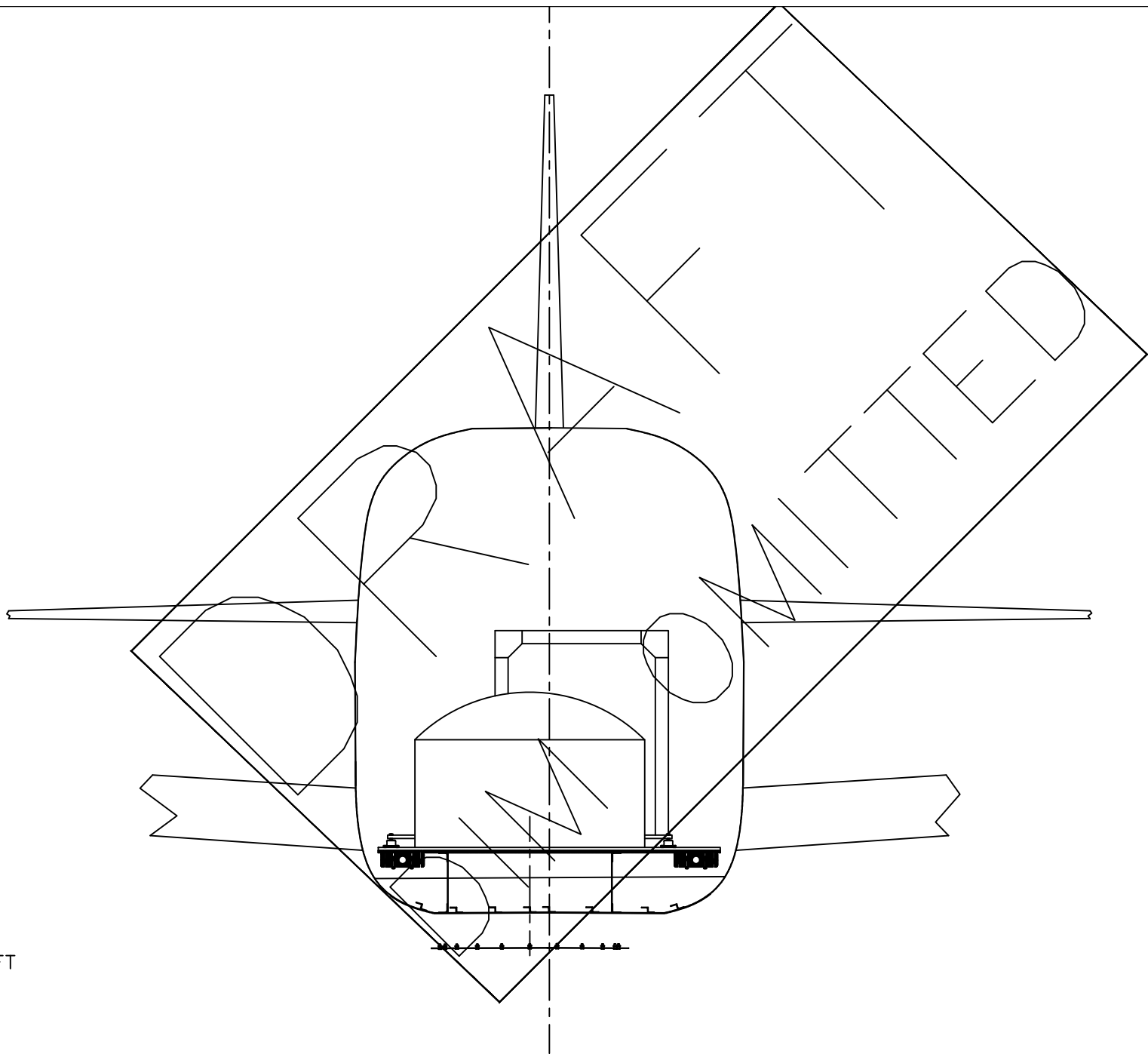

↑  
UP  
LKG AFT

DIMENSIONS ARE IN INCHES  
TOLERANCES:  
.XX = ±.03  
.XXX = ±.015  
ANGLES ±0°-30'

NOTICE - This drawing is the property of Aviation Engineering Consultants of USA, LLC, and any disclosure of its contents to others is given in confidence. It must not be reproduced or copied in whole or in part or used in any way except with specific approval and permission of the General Manager of Aviation Engineering Consultants of USA, LLC.



AVIATION ENGINEERING  
CONSULTANTS of USA, LLC  
Cape Coral, Fl. 33990  
800-977-1992

TITLE PIPER AZTEC CAMERA PROVISIONS & INSTL

DWG. NO.  
00-1500-01-01-xxx REV. -

SCALE NOTED SHEET 6

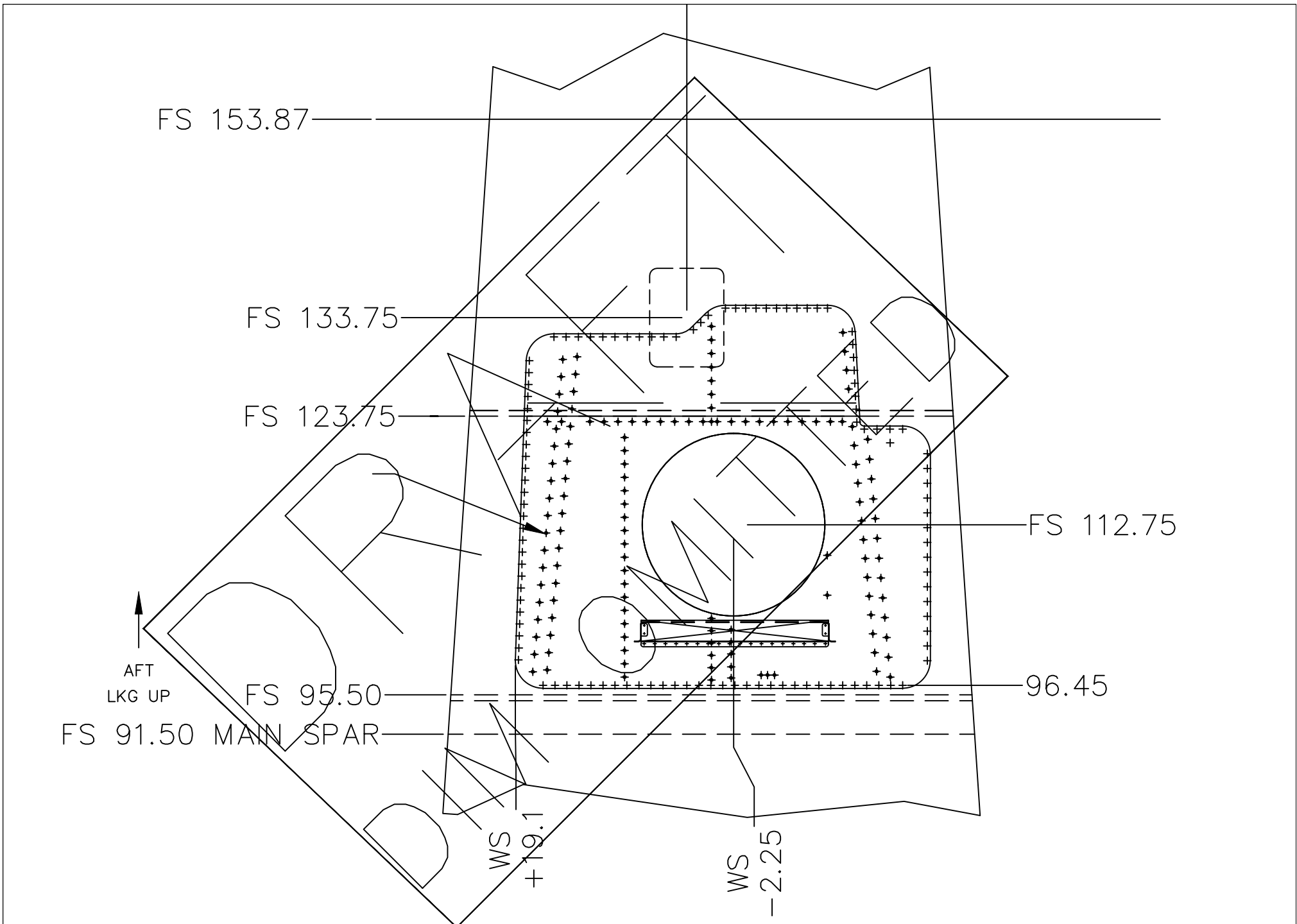

DIMENSIONS ARE IN INCHES  
 TOLERANCES:  
 .XX = ±.03  
 .XXX = ±.015  
 ANGLES ±0°-30'

NOTICE - This drawing is the property of Aviation Engineering Consultants of USA, LLC, and any disclosure of its contents to others is given in confidence. It must not be reproduced or copied in whole or in part or used in any way except with specific approval and permission of the General Manager of Aviation Engineering Consultants of USA, LLC.



AVIATION ENGINEERING  
 CONSULTANTS OF USA, LLC  
 Cape Coral, Fl. 33990  
 800-977-1992

TITLE PIPER AZTEC CAMERA PROVISIONS & INSTL

DWG. NO. 00-1500-01-01-xxx REV. -

SCALE NOTED SHEET 7

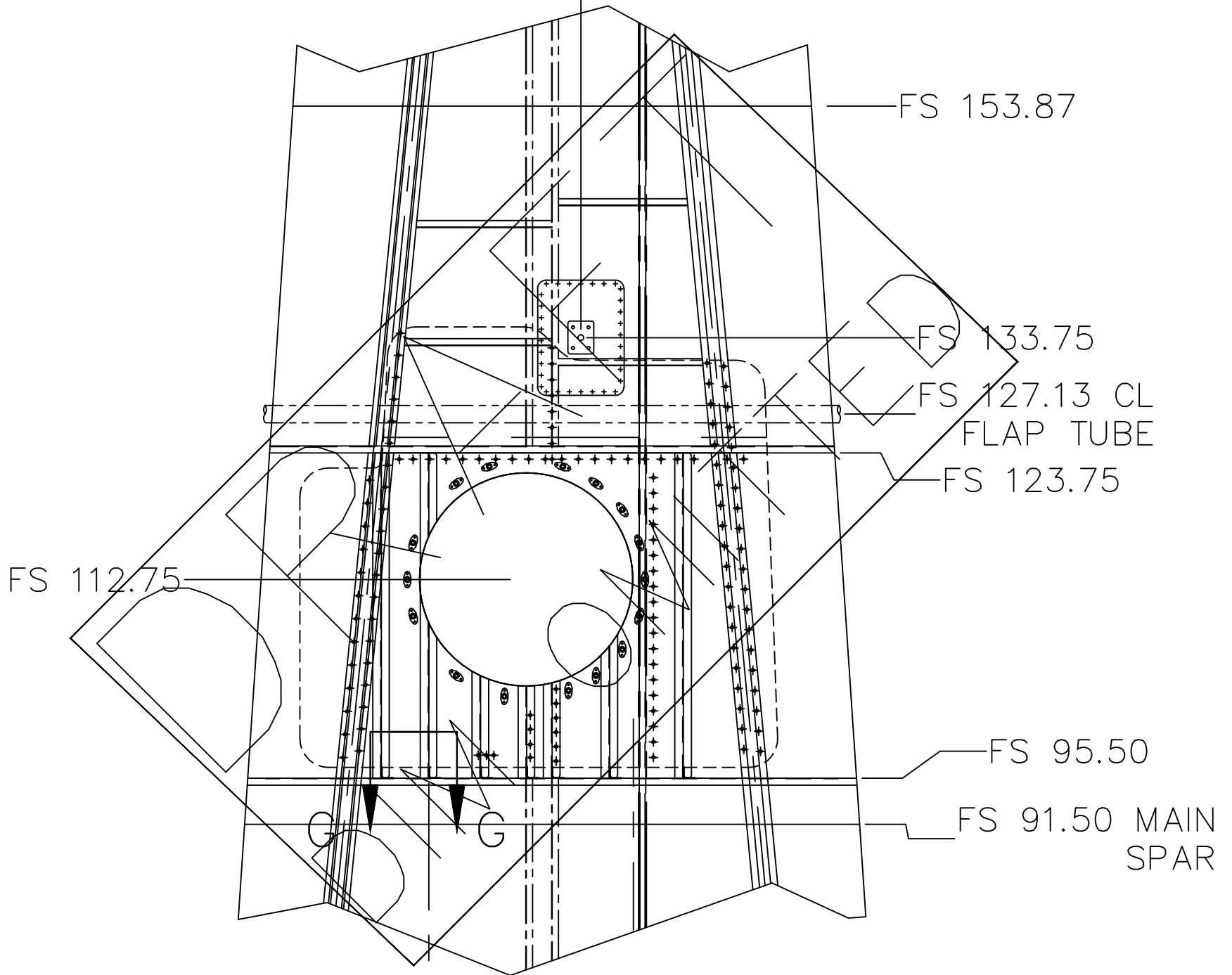

DIMENSIONS ARE IN INCHES  
 TOLERANCES:  
 .XX = ±.03  
 .XXX = ±.015  
 ANGLES ±0°-30'

NOTICE - This drawing is the property of Aviation Engineering Consultants of USA, LLC, and any disclosure of its contents to others is given in confidence. It must not be reproduced or copied in whole or in part or used in any way except with specific approval and permission of the General Manager of Aviation Engineering Consultants of USA, LLC.



AVIATION ENGINEERING  
 CONSULTANTS of USA, LLC  
 Cape Coral, Fl. 33990  
 800-977-1992

TITLE PIPER AZTEC CAMERA PROVISIONS & INSTL

DWG. NO.  
 00-1500-01-01-xxx REV. -

SCALE NOTED SHEET 8

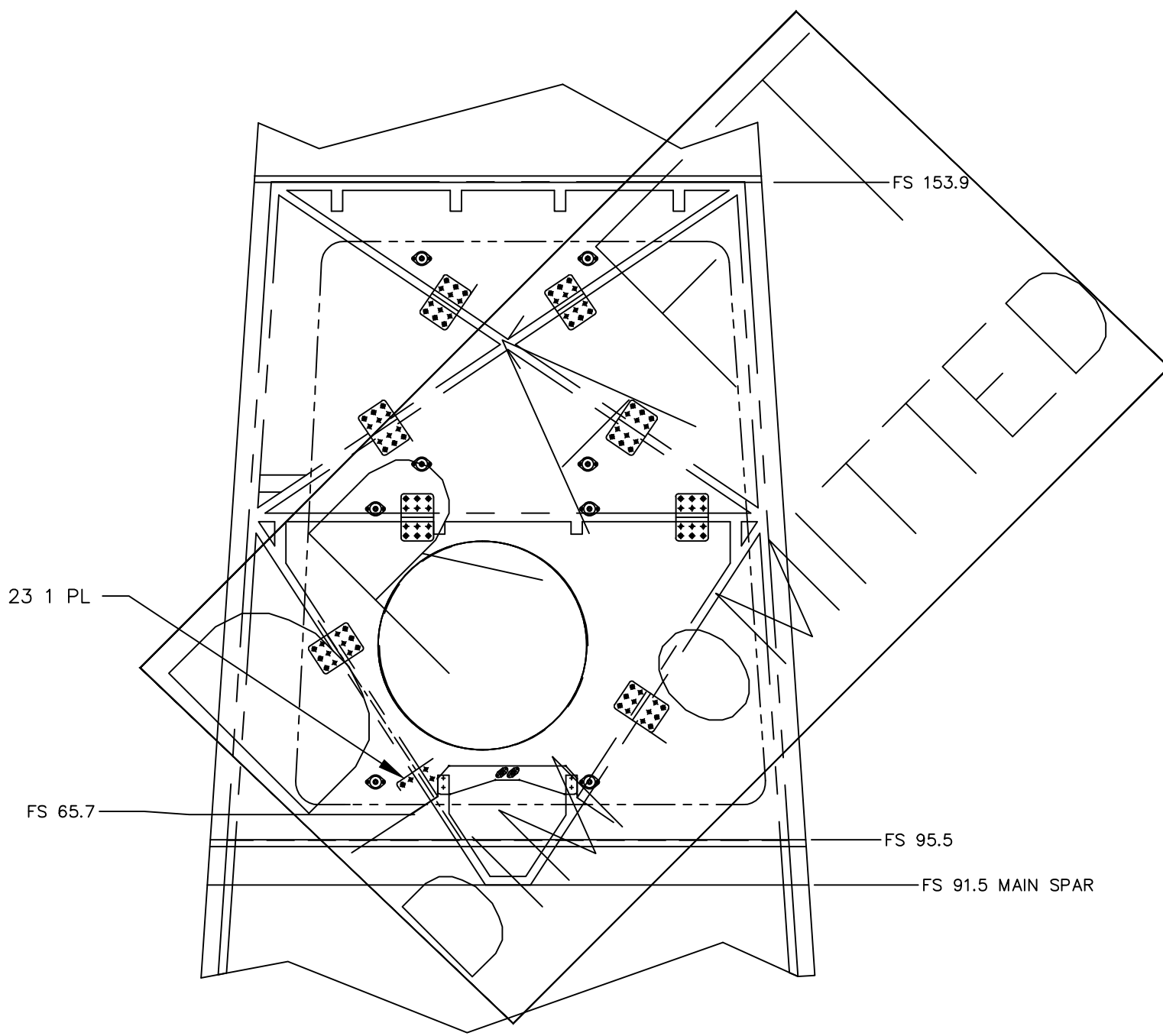

DIMENSIONS ARE IN INCHES  
 TOLERANCES:  
 .XX = ±.03  
 .XXX = ±.015  
 ANGLES ±0°-30'

NOTICE - This drawing is the property of Aviation Engineering Consultants of USA, LLC, and any disclosure of its contents to others is given in confidence. It must not be reproduced or copied in whole or in part or used in any way except with specific approval and permission of the General Manager of Aviation Engineering Consultants of USA, LLC.



AVIATION ENGINEERING  
 CONSULTANTS of USA, LLC  
 Cape Coral, Fl. 33990  
 800-977-1992

TITLE PIPER AZTEC CAMERA PROVISIONS & INSTL

DWG. NO.  
 00-1500-01-01-xxx REV. -

SCALE NOTED SHEET 9

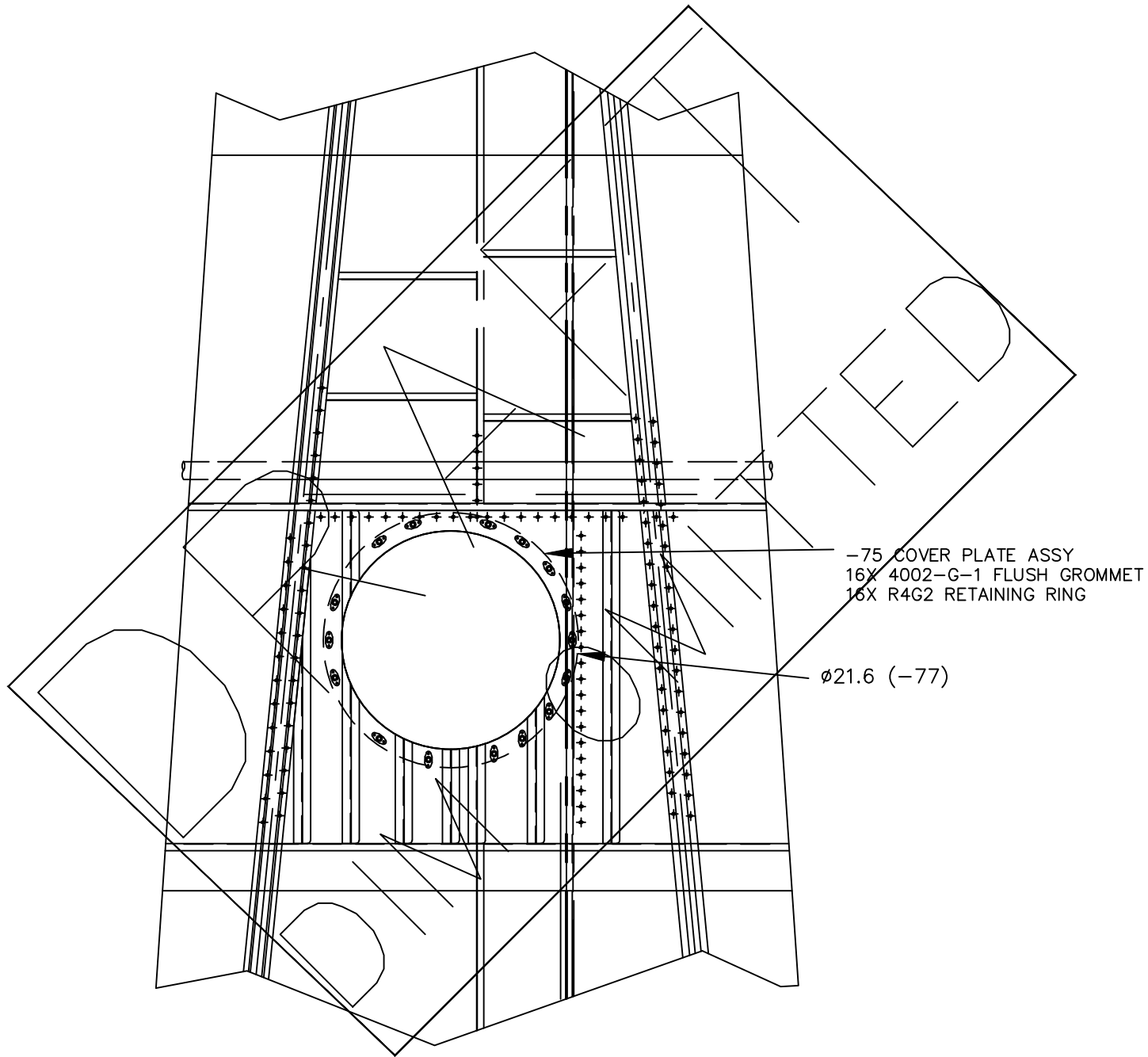

DIMENSIONS ARE IN INCHES  
 TOLERANCES:  
 .XX =  $\pm 0.03$   
 .XXX =  $\pm 0.015$   
 ANGLES  $\pm 0^{\circ}-30'$

NOTICE - This drawing is the property of Aviation Engineering Consultants of USA, LLC, and any disclosure of its contents to others is given in confidence. It must not be reproduced or copied in whole or in part or used in any way except with specific approval and permission of the General Manager of Aviation Engineering Consultants of USA, LLC.



AVIATION ENGINEERING  
 CONSULTANTS of USA, LLC  
 Cape Coral, Fl. 33990  
 800-977-1992

TITLE PIPER AZTEC CAMERA PROVISIONS & INSTL

DWG. NO.  
 00-1500-01-01-xxx REV. -

SCALE NOTED SHEET 10



DIMENSIONS ARE IN INCHES  
 TOLERANCES:  
 .XX = ±.03  
 .XXX = ±.015  
 ANGLES ±0°-30'

NOTICE - This drawing is the property of Aviation Engineering Consultants of USA, LLC, and any disclosure of its contents to others is given in confidence. It must not be reproduced or copied in whole or in part or used in any way except with specific approval and permission of the General Manager of Aviation Engineering Consultants of USA, LLC.



**AVIATION ENGINEERING  
 CONSULTANTS of USA, LLC**  
 Cape Coral, Fl. 33990  
 800-977-1992

TITLE PIPER AZTEC CAMERA PROVISIONS & INSTL

DWG. NO.  
 00-1500-01-01-xxx

REV. -

SCALE NOTED

SHEET 11

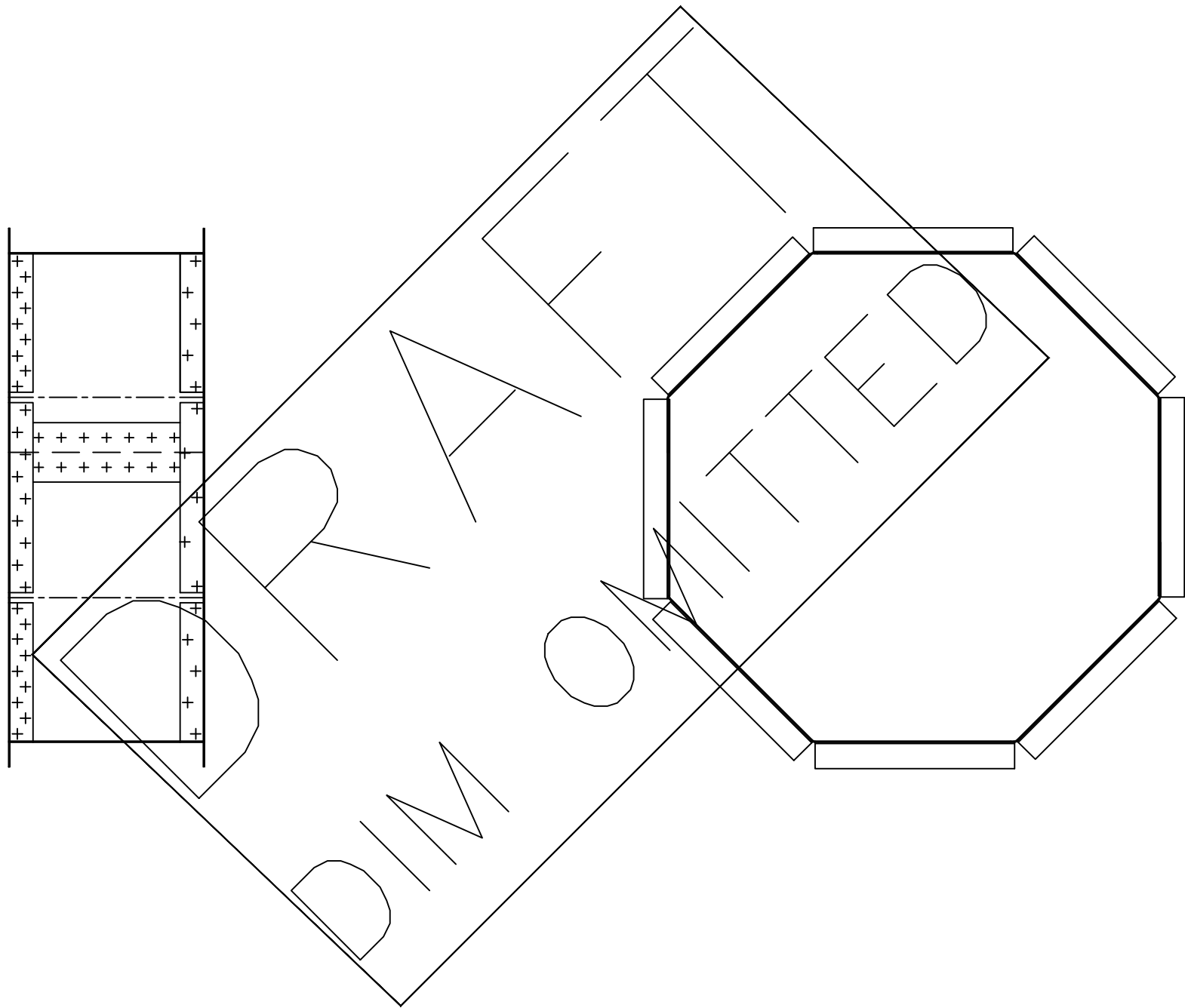

DIMENSIONS ARE IN INCHES  
 TOLERANCES:  
 .XX = ±.03  
 .XXX = ±.015  
 ANGLES ±0°-30'

NOTICE - This drawing is the property of Aviation Engineering Consultants of USA, LLC, and any disclosure of its contents to others is given in confidence. It must not be reproduced or copied in whole or in part or used in any way except with specific approval and permission of the General Manager of Aviation Engineering Consultants of USA, LLC.



**AVIATION ENGINEERING  
 CONSULTANTS of USA, LLC**  
 Cape Coral, Fl. 33990  
 800-977-1992

TITLE PIPER AZTEC CAMERA PROVISIONS & INSTL

DWG. NO.  
 00-1500-01-01-xxx

REV. -

SCALE NOTED

SHEET 12

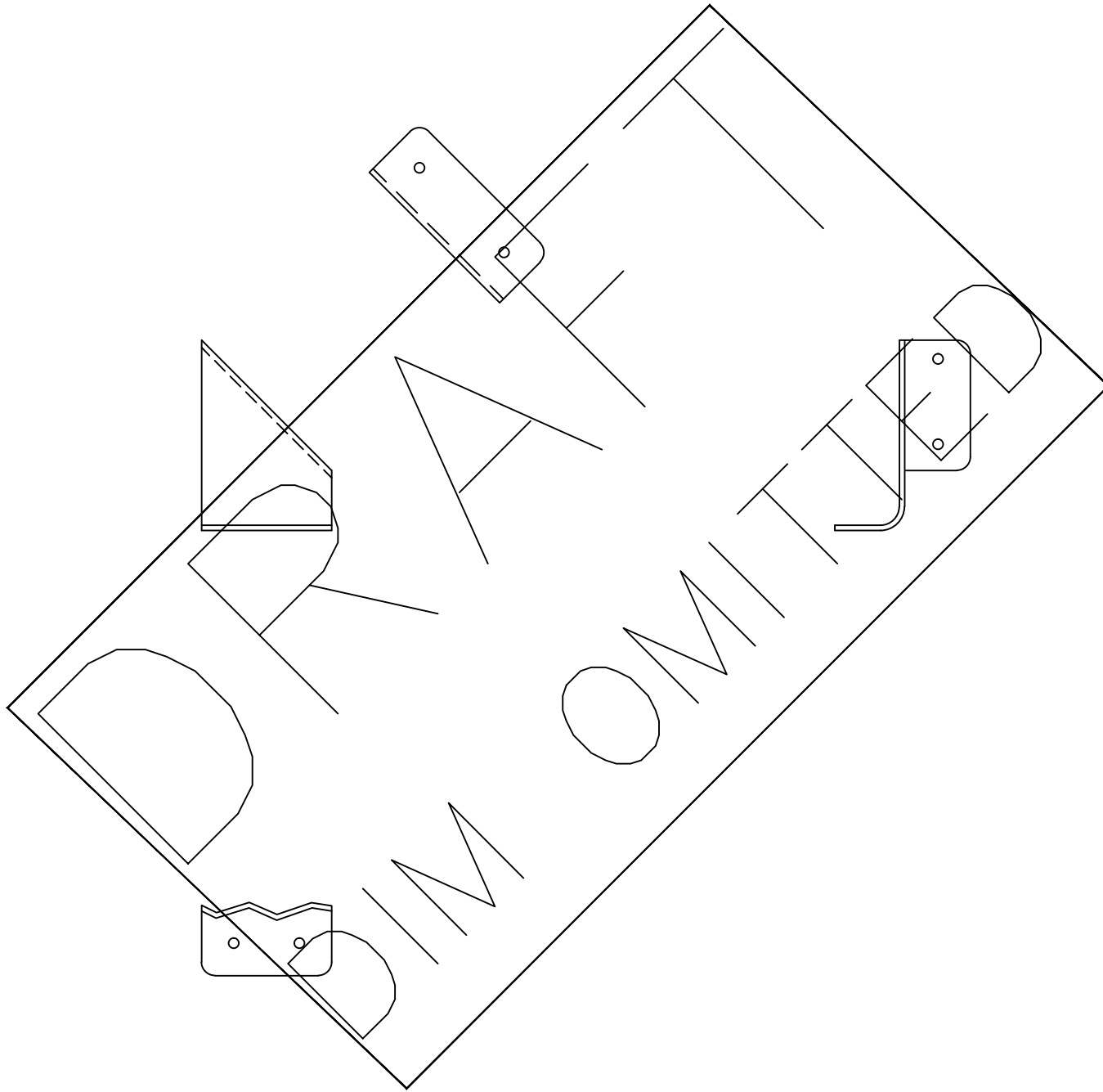

DIMENSIONS ARE IN INCHES  
 TOLERANCES:  
 .XX = ±.03  
 .XXX = ±.015  
 ANGLES ±0°-30'

NOTICE - This drawing is the property of Aviation Engineering Consultants of USA, LLC, and any disclosure of its contents to others is given in confidence. It must not be reproduced or copied in whole or in part or used in any way except with specific approval and permission of the General Manager of Aviation Engineering Consultants of USA, LLC.



**AVIATION ENGINEERING  
 CONSULTANTS of USA, LLC**  
 Cape Coral, Fl. 33990  
 800-977-1992

TITLE PIPER AZTEC CAMERA PROVISIONS & INSTL

DWG. NO.  
 00-1500-01-01-xxx REV. -

SCALE NOTED SHEET 13



DIMENSIONS ARE IN INCHES  
 TOLERANCES:  
 .XX = ±.03  
 .XXX = ±.015  
 ANGLES ±0°-30'

NOTICE - This drawing is the property of Aviation Engineering Consultants of USA, LLC, and any disclosure of its contents to others is given in confidence. It must not be reproduced or copied in whole or in part or used in any way except with specific approval and permission of the General Manager of Aviation Engineering Consultants of USA, LLC.



**AVIATION ENGINEERING  
 CONSULTANTS of USA, LLC**  
 Cape Coral, Fl. 33990  
 800-977-1992

TITLE PIPER AZTEC CAMERA PROVISIONS & INSTL

DWG. NO.  
 00-1500-01-01-xxx REV. -

SCALE NOTED

SHEET 14

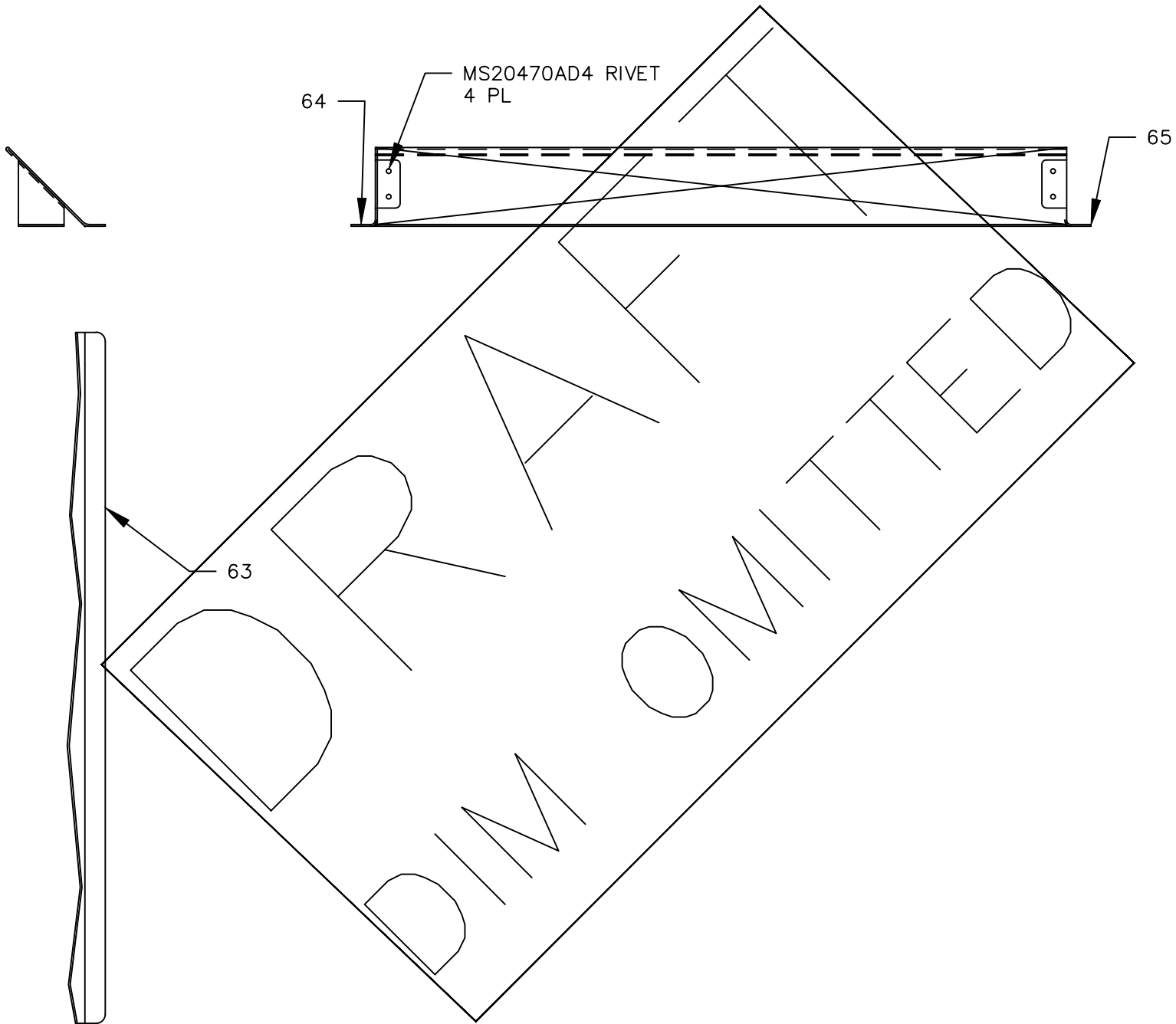

DIMENSIONS ARE IN INCHES  
 TOLERANCES:  
 .XX = ±.03  
 .XXX = ±.015  
 ANGLES ±0°-30'

NOTICE - This drawing is the property of Aviation Engineering Consultants of USA, LLC, and any disclosure of its contents to others is given in confidence. It must not be reproduced or copied in whole or in part or used in any way except with specific approval and permission of the General Manager of Aviation Engineering Consultants of USA, LLC.



AVIATION ENGINEERING  
 CONSULTANTS of USA, LLC  
 Cape Coral, Fl. 33990  
 800-977-1992

TITLE PIPER AZTEC CAMERA PROVISIONS & INSTL

DWG. NO.  
 00-1500-01-01-xxx REV. -

SCALE NOTED SHEET 15

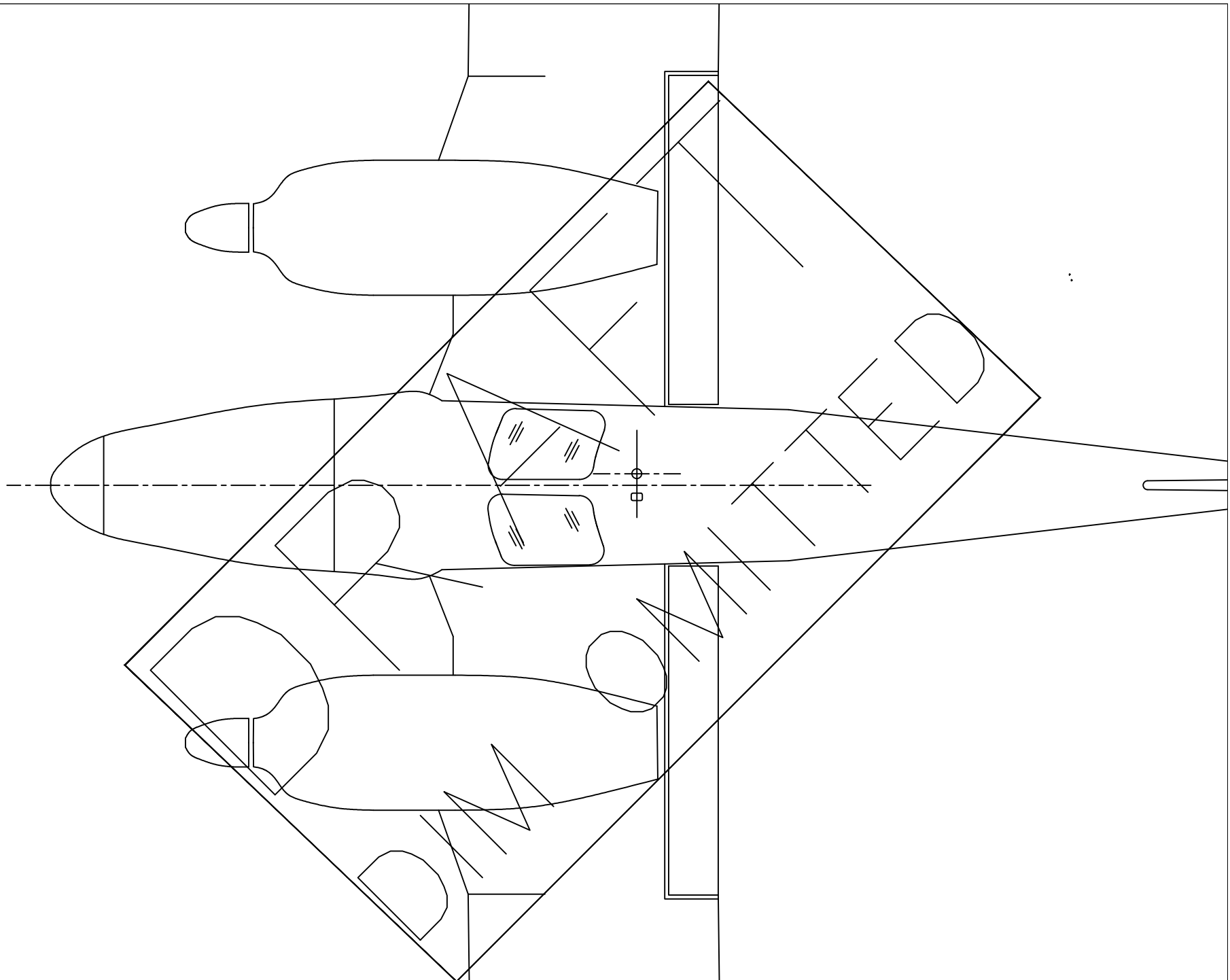

DIMENSIONS ARE IN INCHES  
 TOLERANCES:  
 .XX = ±.03  
 .XXX = ±.015  
 ANGLES ±0°-30'

NOTICE - This drawing is the property of Aviation Engineering Consultants of USA, LLC, and any disclosure of its contents to others is given in confidence. It must not be reproduced or copied in whole or in part or used in any way except with specific approval and permission of the General Manager of Aviation Engineering Consultants of USA, LLC.

**στ** AVIATION ENGINEERING  
 CONSULTANTS of USA, LLC  
 Cape Coral, Fl. 33990  
 800-977-1992

TITLE PIPER AZTEC CAMERA PROVISIONS & INSTL		SCALE NOTED	SHEET 16
DWG. NO.	REV. -		
00-1500-01-01-xxx			

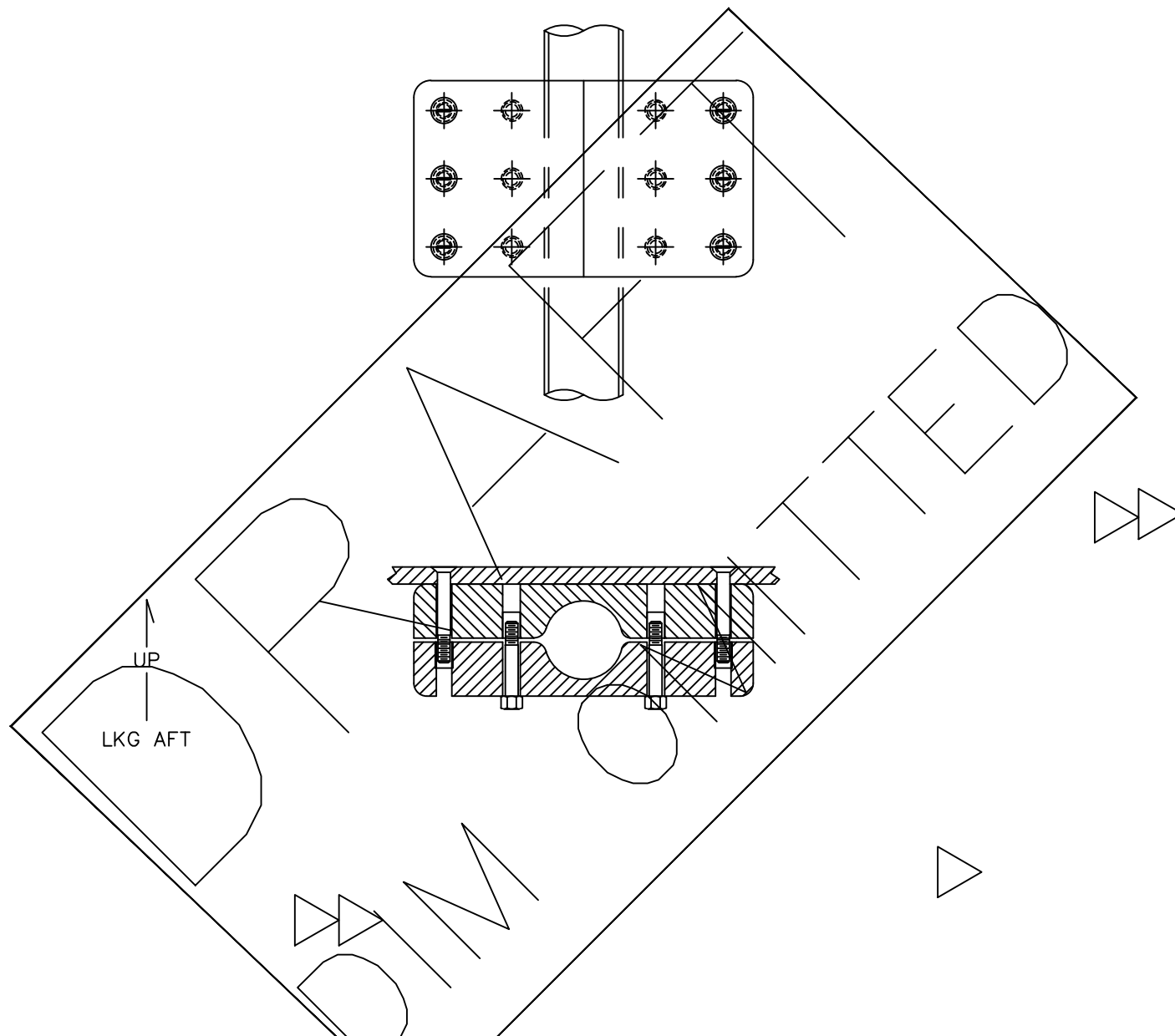

DIMENSIONS ARE IN INCHES  
 TOLERANCES:  
 .XX = ±.03  
 .XXX = ±.015  
 ANGLES ±0°-30'

NOTICE - This drawing is the property of Aviation Engineering Consultants of USA, LLC, and any disclosure of its contents others is given in confidence. It must not be reproduced or copied in whole or in part or used in any way except with specific approval and permission of the General Manager of Aviation Engineering Consultants of USA, LLC.



**AVIATION ENGINEERING  
 CONSULTANTS of USA, LLC**  
 Cape Coral, Fl. 33990  
 800-977-1992

TITLE PIPER AZTEC CAMERA PROVISIONS & INSTL

DWG. NO.  
 00-1500-01-01-xxx

REV. -

SCALE NOTED

SHEET 17

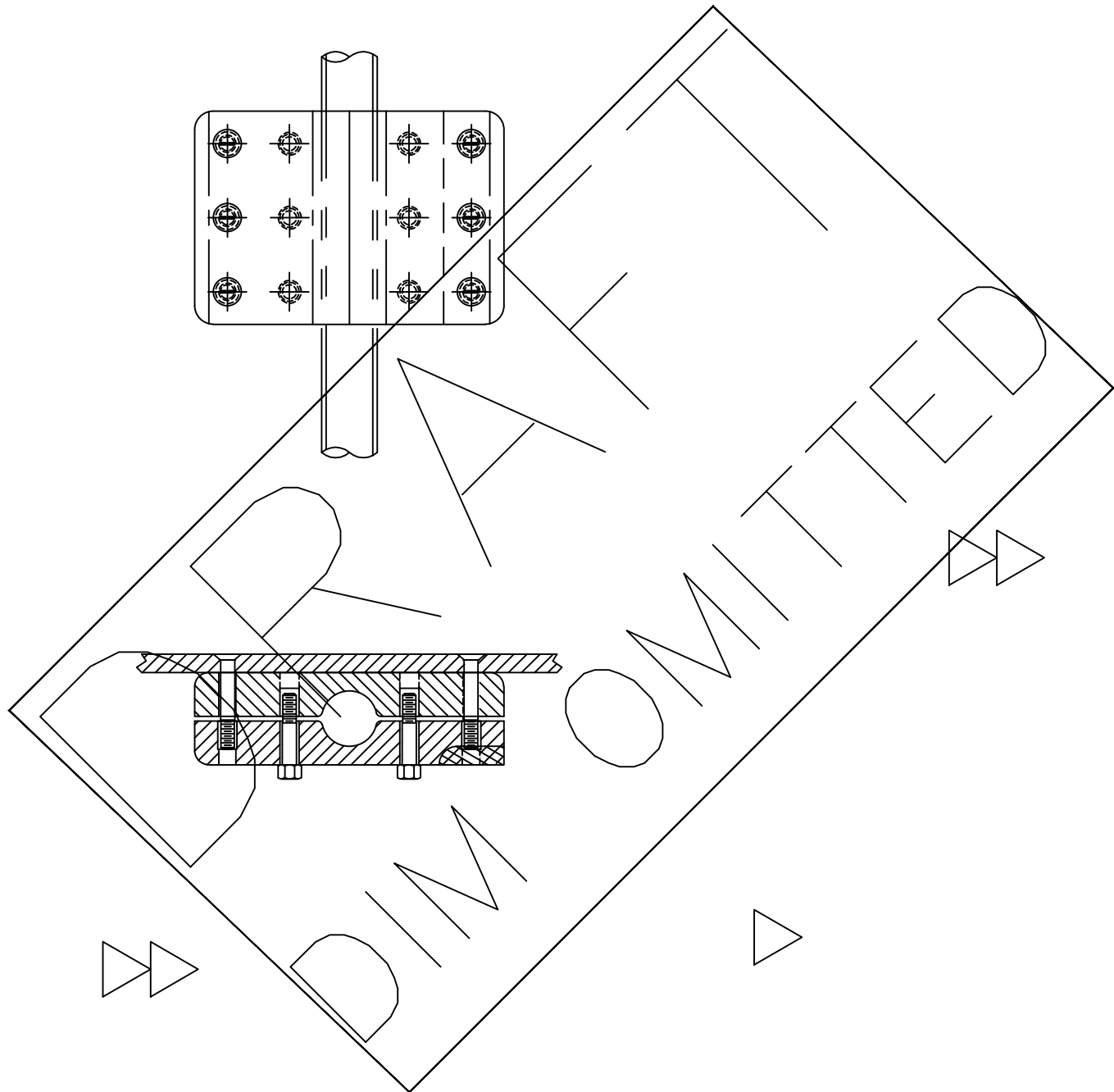

UP  
LKG AFT

DIMENSIONS ARE IN INCHES  
TOLERANCES:  
.XX = ±.03  
.XXX = ±.015  
ANGLES ±0°-30'

NOTICE - This drawing is the property of Aviation Engineering Consultants of USA, LLC, and any disclosure of its contents to others is given in confidence. It must not be reproduced or copied in whole or in part or used in any way except with specific approval and permission of the General Manager of Aviation Engineering Consultants of USA, LLC.



AVIATION ENGINEERING  
CONSULTANTS of USA, LLC  
Cape Coral, Fl. 33990  
800-977-1992

TITLE PIPER AZTEC CAMERA PROVISIONS & INSTL

DWG. NO.  
00-1500-01-01-xxx REV. -

SCALE NOTED SHEET 18

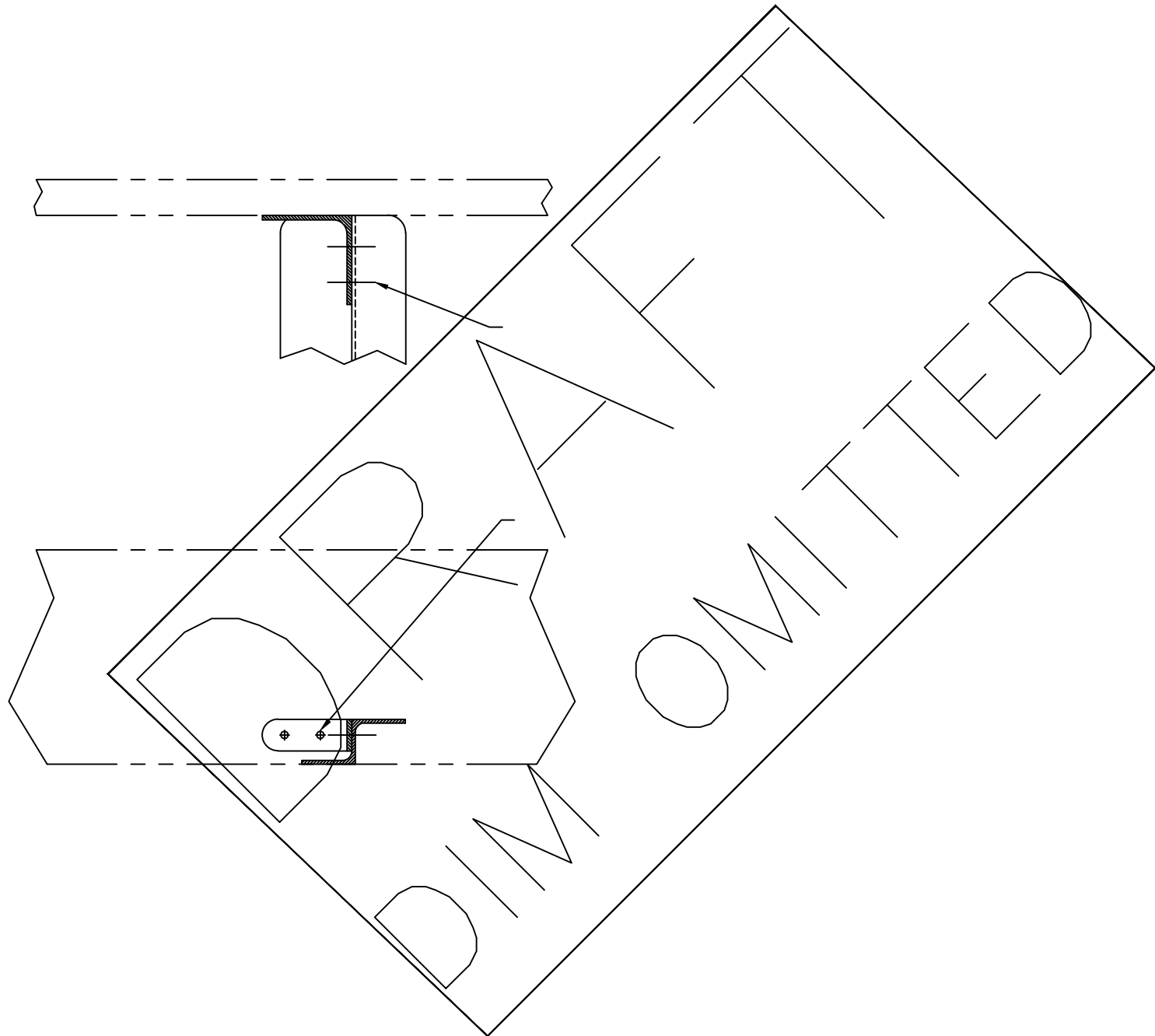

DIMENSIONS ARE IN INCHES  
 TOLERANCES:  
 .XX = ±.03  
 .XXX = ±.015  
 ANGLES ±0°-30'

NOTICE - This drawing is the property of Aviation Engineering Consultants of USA, LLC, and any disclosure of its contents to others is given in confidence. It must not be reproduced or copied in whole or in part or used in any way except with specific approval and permission of the General Manager of Aviation Engineering Consultants of USA, LLC.



**AVIATION ENGINEERING  
 CONSULTANTS of USA, LLC**  
 Cape Coral, Fl. 33990  
 800-977-1992

TITLE PIPER AZTEC CAMERA PROVISIONS & INSTL

DWG. NO.  
 00-1500-01-01-xxx REV. -

SCALE NOTED SHEET 19

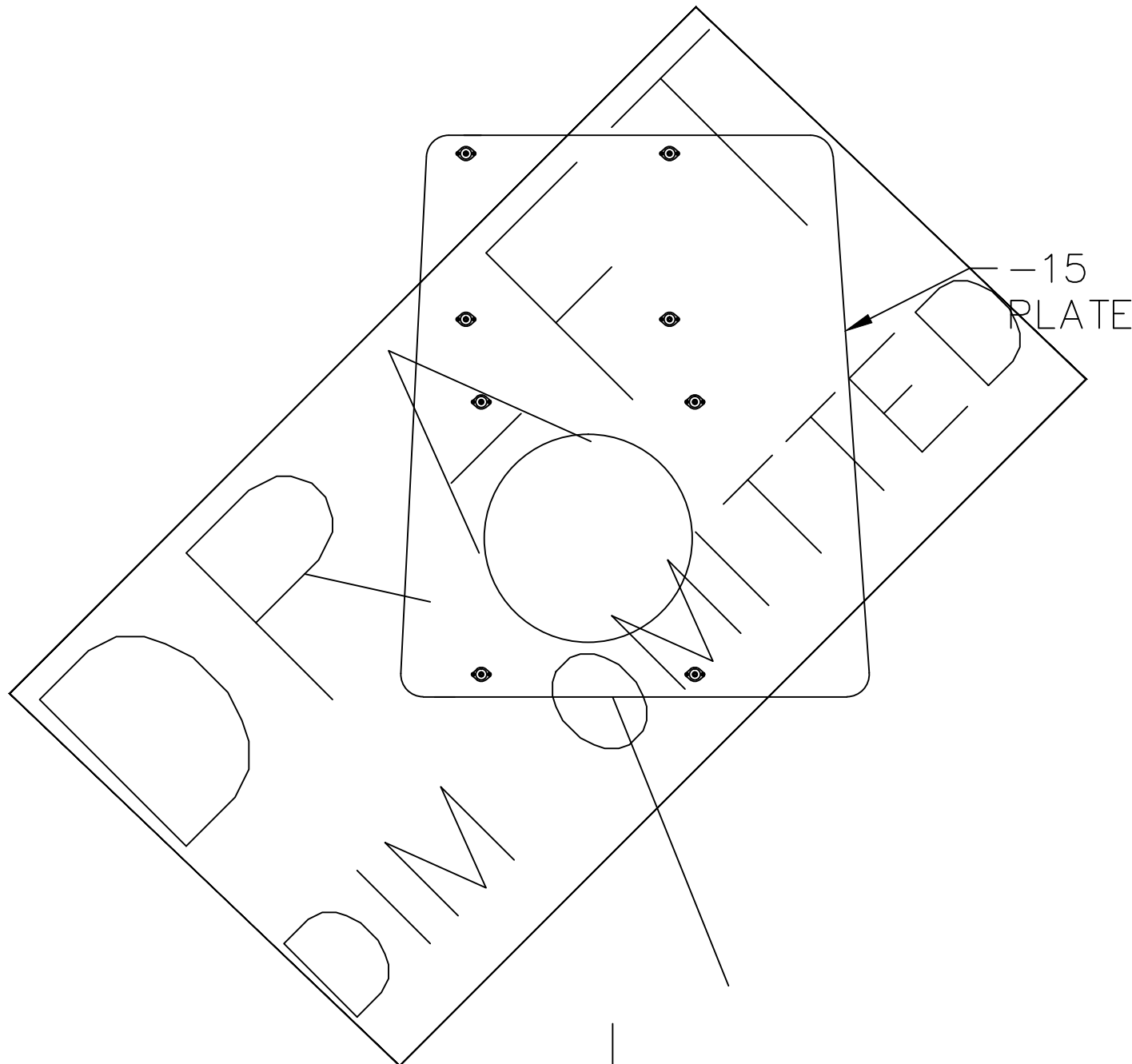
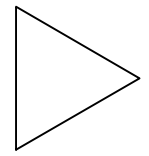

-15  
PLATE

DIMENSIONS ARE IN INCHES  
TOLERANCES:  
.XX = ±.03  
.XXX = ±.015  
ANGLES ±0°-30'

NOTICE - This drawing is the property of Aviation Engineering Consultants of USA, LLC, and any disclosure of its contents to others is given in confidence. It must not be reproduced or copied in whole or in part or used in any way except with specific approval and permission of the General Manager of Aviation Engineering Consultants of USA, LLC.

**στ** AVIATION ENGINEERING  
CONSULTANTS of USA, LLC  
Cape Coral, Fl. 33990  
800-977-1992

TITLE PIPER AZTEC CAMERA PROVISIONS & INSTL

DWG. NO.  
00-1500-01-01-xxx REV. -

SCALE NOTED SHEET 20

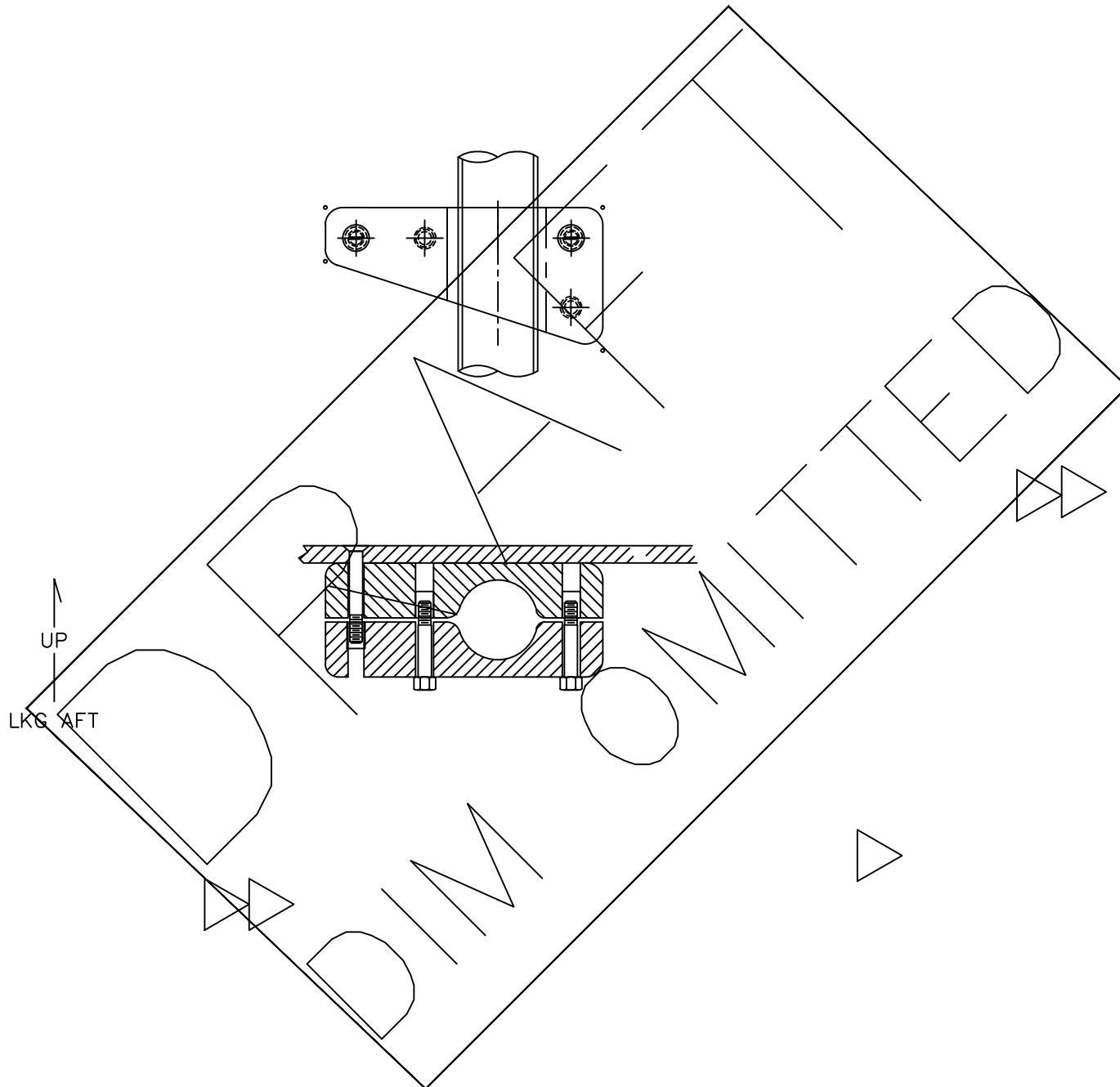

DIMENSIONS ARE IN INCHES  
 TOLERANCES:  
 .XX = ±.03  
 .XXX = ±.015  
 ANGLES ±0°-30'

NOTICE - This drawing is the property of Aviation Engineering Consultants of USA, LLC, and any disclosure of its contents to others is given in confidence. It must not be reproduced or copied in whole or in part or used in any way except with specific approval and permission of the General Manager of Aviation Engineering Consultants of USA, LLC.

**στ** AVIATION ENGINEERING  
 CONSULTANTS of USA, LLC  
 Cape Coral, Fl. 33990  
 800-977-1992

TITLE PIPER AZTEC CAMERA PROVISIONS & INSTL		SCALE NOTED	SHEET 21
DWG. NO. 00-1500-01-01-xxx	REV. -		